

CL Challenger Lifts



Model#: CS1020WV
Versymmetric® inground lift
10,000 lb. lifting capacity

CS1020WV

Versymmetric®
Technology

A superior arm sweep, the widest drive-thru in the industry plus more service bays (smaller footprint than surface lifts) means even more revenue. CS1020WV EnviroLift™ cassette-style inground lift meets all the demands of a professional service facility.

CS1020WV services more vehicles with its double telescoping screw pads, Versymmetric® 3-stage arms and wide drive-thru. It protects your investment and the environment with its fully contained polymer housing made from recycled plastic (No EPA concerns). It also creates a professional showroom style appearance with its open aesthetically pleasing look.

Features & Benefits:

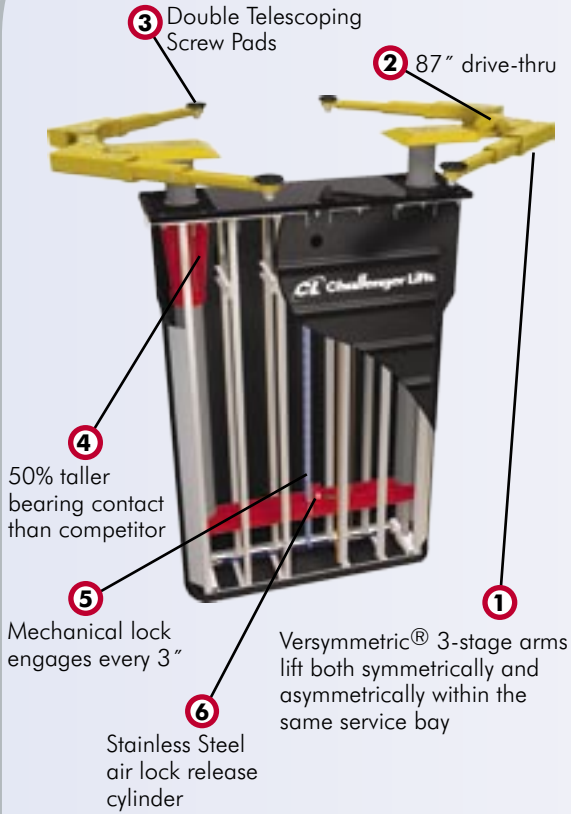

- 1 Maximize service capabilities and revenue potential
- 2 Widest industry drive-thru eases vehicle spotting
- 3 Standard foot pad range reduces the need for truck adapters
- 4 Provides increased stability
- 5 Allows technician to work at their ergonomic working height to increase productivity and minimize fatigue
- 6 Promotes longer working life with its corrosion resistant design

For more information, contact your Authorized Challenger Lifts Distributor:

CS1020WV	Specifications
Lifting Capacity	10000 lb. (4536kg)
Stroke	68" (1727mm)
A Rise Height ¹	75" (1905mm)
B Width Overall	110" (2794mm)
C Drive-Thru Clearance	87" (2210mm)
D Reach (Arm Minimum)	19 ⁵ / ₈ " (498mm)
E Reach (Arm Maximum)	42" (1067mm)
F Rubber Pad Adapter Min. ²	3 ⁷ / ₈ " (98mm)
G Rubber Pad Adapter Max. ²	7 ¹ / ₈ " (181mm)
Capacity (Per Arm)	2500 lb. (1134kg)
Motor	2HP
Voltage (Single Phase Std.) ³	208v-230v
Speed of Rise	48 Seconds
Air Required	75 - 125 psi
Recommended Ceiling Height	79" (2007mm) plus height of tallest vehicle

- 1 Rise height is measured with superstructure in highest position.
- 2 Specifications are listed without rubber pad, for measurements with rubber pad add 1/4" (6mm).
- 3 Optional 3 phase power unit also available, please specify at time of order.

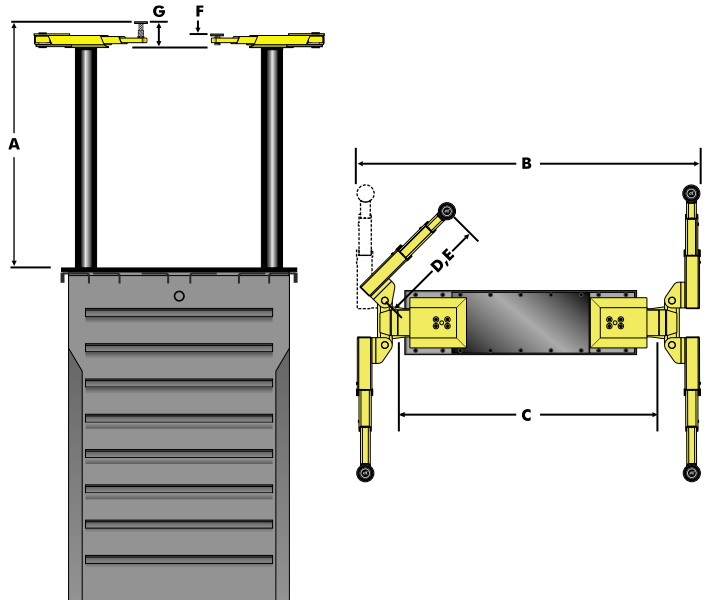

The Automotive Lift Institute (ALI) certifies that the CS1020WV described herein complies with the applicable provisions of the American National Standards ANSI/ALI ALCTV 2006 and is Third Party Validated by the ETL Testing Laboratory.

CHALLENGER LIFTS, INC. Phone Toll-Free: 800-648-5438
 200 Cabel Street 502-625-0700
 Louisville, Kentucky 40206 Fax: 502-625-0711
 E-mail: sales@challengerylifts.com

Challenger Lifts, Inc. reserves the right to make changes to specifications without notice and without making changes retroactive. Unloading, installation and oil not included.