

# CL Challenger Lifts

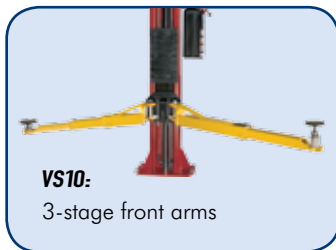

**Model#: VS10**  
Versymmetric® 2-Post Lift  
Symmetric application  
10,000 lb. capacity

## VS10



**VS10:**  
3-stage front arms

**Versymmetric®**  
**Technology**

The VS10 features Challenger's innovative Versymmetric® Technology, providing technicians the versatility to lift vehicles both symmetrically and asymmetrically within the same service bay. This exclusive technology facilitates increased efficiency and revenue potential.

With adjustable height and width options, double telescoping screw pads, durable powder coat finish, plated arm restraints and pins and many other appealing features, the VS10 will accommodate the rigorous demands of a full service facility and afford room to grow with its reasonable cost. Available in red and blue.

## Features & Benefits:

- Versymmetric® 3-stage front arms provide greater overall arm sweep for:
  - » Asymmetric or Symmetric lifting in the same service bay
  - » Uni-body design vehicles
  - » Vehicles with designated outside pick up points
  - » Wider vehicles
  - » Low profile vehicles
  - » Both short and long wheelbases
- Adjustable height and width options accommodate varying service bay sizes
- Double Telescoping Screw Pads adjust to multiple heights minimizing the need for adapters
- Rubber foot pads minimize stress to vehicles with delicate undercoatings
- Padded overhead shut off system prevents vehicle damage
- Single-point mechanical lock release system allows technician to disengage both columns simultaneously
- Wide rubber door guards protect vehicle from door damage
- Premium powder coat finish provides long-lasting durability
- Plated Arm Restraints and Arm Pins inhibit rust and provide long-lasting durability

For more information, contact your Authorized Challenger Lifts Distributor:

VS10	Specifications
Lifting Capacity*	10,000 lb. (4536kg)
<b>A</b> Rise Height <sup>1</sup>	76" (1930mm)
<b>B</b> Column Height (min/max)	11' 11 1/2" / 12' 5 1/2" (3645mm / 3797mm)
Cylinder Height at Full Rise	12' 1 3/8" (3693mm)
<b>C</b> Adj. Overall Width (min/max)	10' 11" / 11' 4 3/4" (3327mm / 3473mm)
<b>D</b> Drive-thru Clearance (min/max)	92 3/8" / 98 3/8" (2346mm / 2499mm)
<b>E</b> Floor to Overhead Switch (min/max)	11' 6" - 12' (3505mm - 3658mm)
<b>F</b> Front Arm Reach (min/max)	22 1/8" / 41 1/2" (562mm / 1054mm)
<b>G</b> Rear Arm Reach (min/max)	38 5/8" / 61 3/8" (981mm / 1559mm)
<b>H</b> Screw Pad Height (min/max) <sup>2</sup>	3 7/8" - 7 1/8" (98mm-181mm)
<b>I</b> Inside of Columns (min/max)	104 1/2" / 110 1/2" (2654mm / 2807mm)
Ceiling Height Required <sup>3</sup> (min/max)	12' 2" / 12' 6 1/2" (3708mm / 3823mm)
Motor	2HP, Single Phase, 60Hz
Voltage	208 - 230v
Speed of Rise	52 seconds
Max. Load Per Arm	2,500 lb. (1134kg)

\*Lift capacity ratings are based on loads equally distributed on all four arms.

<sup>1</sup> Rise height is measured with adjustable screw pads in highest position.

<sup>2</sup> Specifications are listed without rubber pad, for measurements with rubber pad add 1/4" (6mm).

<sup>3</sup> Ceiling Height required is 12' 2" when lift column height is configured at minimum height and 12' 6" when configured at maximum height.

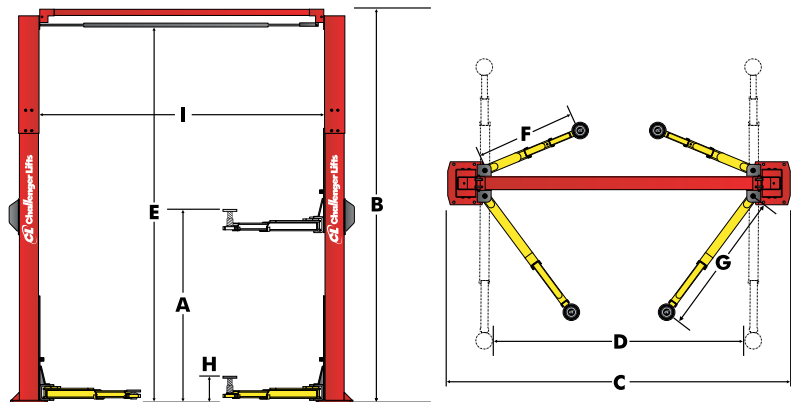

The Automotive Lift Institute (ALI) certifies that the VS10 described herein complies with the applicable provisions of the American National Standards ANSI/ALI ALCTV 2006 and is Third Party Validated by the ETL Testing Laboratory.

CHALLENGER LIFTS, INC.  
200 Cabel Street  
Louisville, Kentucky 40206

Phone Toll-Free: 800-648-5438  
502-625-0700  
Fax: 502-625-0711  
E-mail: sales@challengelifts.com

Challenger Lifts, Inc. reserves the right to make changes to specifications without notice and without making changes retroactive. Unloading, installation and oil not included.